

| REVISIONS | | | |
|-----------|---|-----------|----------|
| REV. | DESCRIPTION | DATE | APPROVED |
| - | NEW RELEASE | - | |
| 1 | MOUNTING BRACKET WAS FABRICATED NOW PURCHASED. PLATE WASHERS WERE FABRICATED NOW PURCHASED. | 4/21/2026 | |

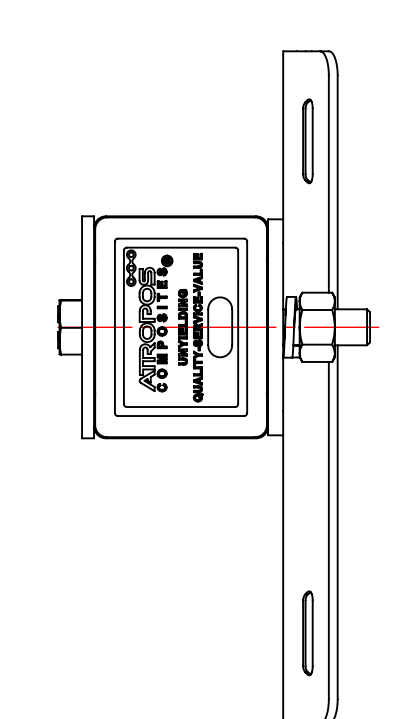
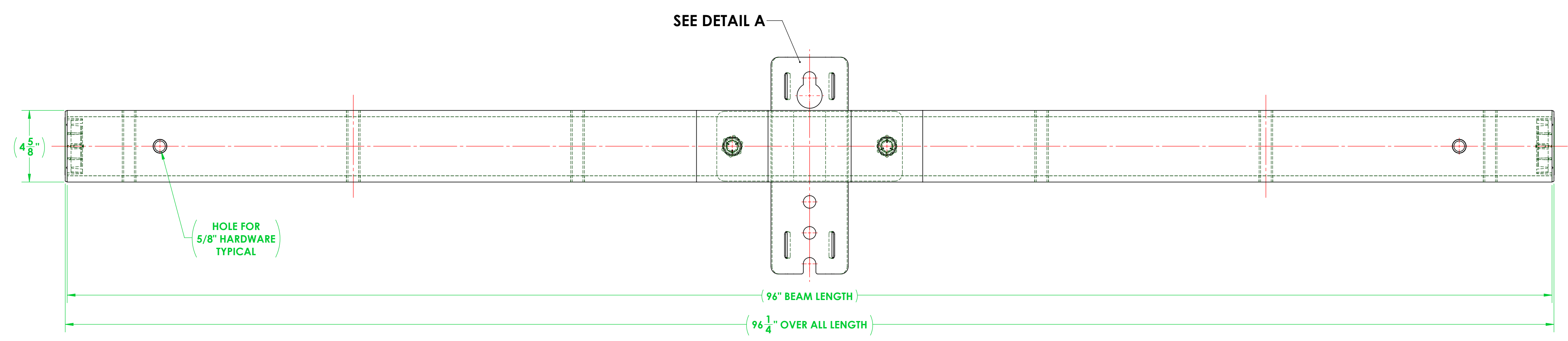
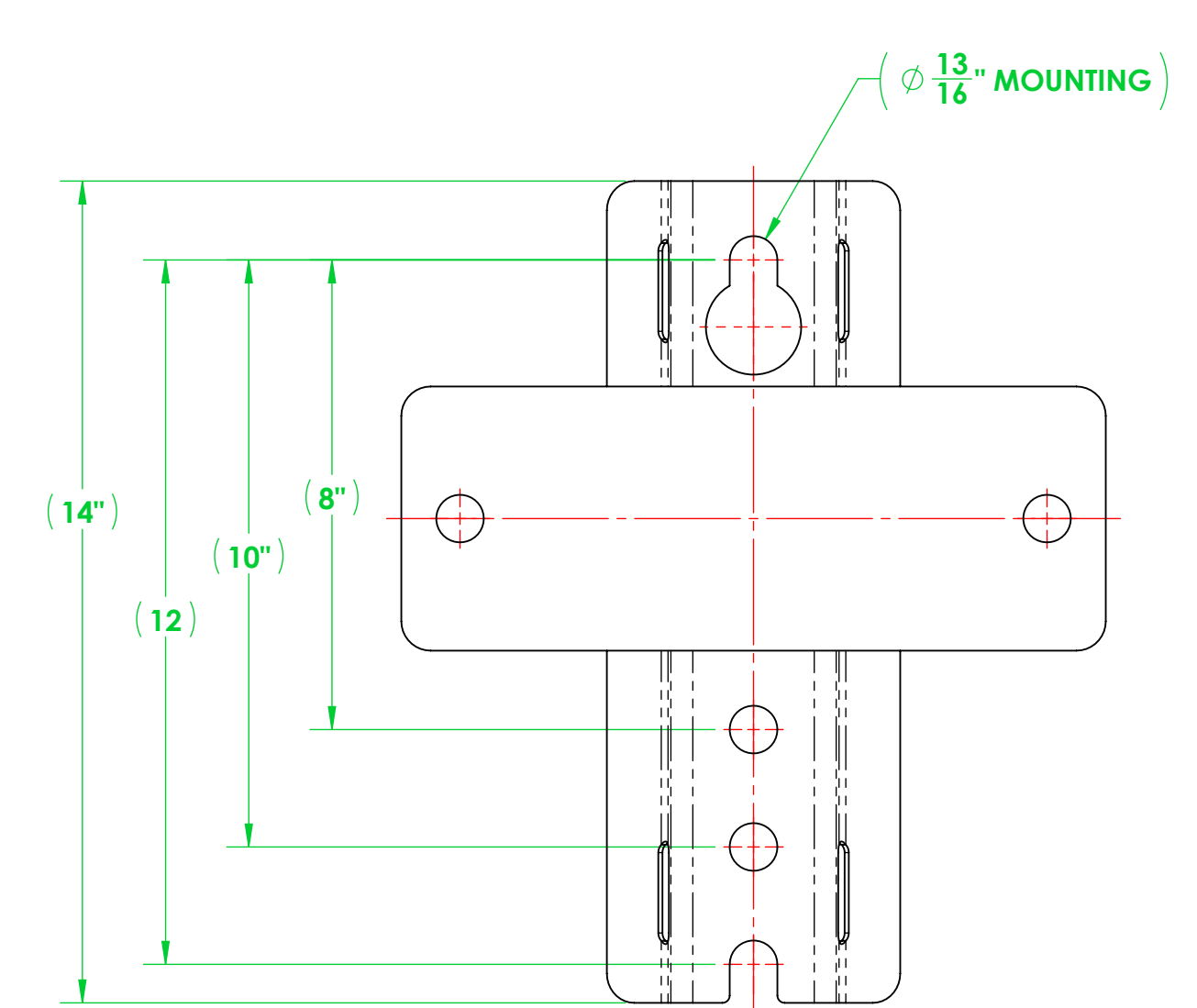
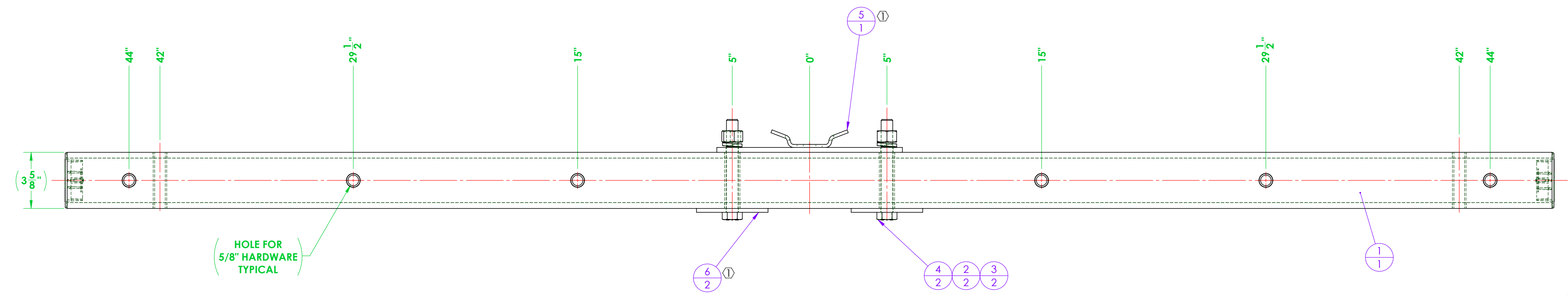

| ITEM NO. | PART NUMBER | DESCRIPTION | QTY. |
|----------|-----------------------|--|------|
| 1 | 3403A096-T011-XR04 CA | ASSEMBLY, RUS, 3403 TANGENT CROSSARM, 8' LONG TYPE 4 DRILL PATTERN | 1 |
| 2 | A616-0042-01 | LOCK WASHER, FOR 3/4" SCREW, 0.766" ID, 1.265" OD, 0.188" THICK, HOT-DIPPED GALVANIZED STEEL | 2 |
| 3 | A616-0019-02 | EXTREME STRENGTH NUT, HEX, 3/4"-10, 2H, HOT-DIPPED GALVANIZED | 2 |
| 4 | A616-0020-02 | BOLT, HEX, 3/4"-10 X 6.00" LONG, HOT DIPPED GALVANIZED STEEL, 1-1/8" DRIVE | 2 |
| ① 5 | A700-0042 | CROSSARM MOUNTING BRACKET, TANGENT, 3400 SERIES | 1 |
| ① 6 | A700-0047 | WASHER, SQUARE, 4.625" X 4.625" X 0.25 THICK WITH 0.81 THRU HOLE | 2 |

GENERAL NOTES

UNLESS OTHERWISE SPECIFIED:
 DIMENSIONS ARE IN INCHES
 STANDARD TOLERANCES:
 FRACTIONAL: $\pm 1/32$
 ANGULAR: MACHINED: $\pm 0.5^\circ$ BEND: $\pm 2^\circ$
 TWO PLACE DECIMAL: ± 0.03
 THREE PLACE DECIMAL: ± 0.005
 INTERPRET GEOMETRIC TOLERANCING PER ANSI Y14.5

NAME: F. BRYANT
 DATE: 10/14/2025
 CHECKED: TJS
 10/21/2025
 ENG APPR:
 MFG APPR:
 Q.A.:

ATROPOS COMPOSITES
 12208 MISSOURI BOTTOM ROAD, HAZELWOOD, MO 63042
 PHONE: 314.714.4001 FAX: 314.895.1943
 SALES@LABYRINTH-TECH.COM

TITLE:
 ASSEMBLY, RUS, 3403, TANGENT CROSSARM WITH GAIN, 8' TYPE 4 DRILL PATTERN

SCALE: 1:8 WEIGHT: 69.45 SHEET 1 OF 1

DO NOT SCALE DRAWING

THE INFORMATION CONTAINED IN THIS DRAWING IS THE SOLE PROPERTY OF VETCOR. ANY REPRODUCTION IN PART OR AS A WHOLE WITHOUT THE WRITTEN PERMISSION OF VETCOR IS PROHIBITED.

PROPRIETARY AND CONFIDENTIAL

SIZE DWG. NO. REV
D 3403A096-T011-XR04 1